



aerospace
climate control
electromechanical
filtration
fluid & gas handling
hydraulics
pneumatics
process control
welding & shielding



HCS Spreader Control Valves

Manual and Electronic Catalog



ENGINEERING YOUR SUCCESS.



PSM1000

Parker Spread Master System **A Complete Salt and Sand Control System**

Parker Hannifin introduces the
Model PSM1000 Parker Spread Master System
designed to provide reliable application of salt and sand with
remote electronics and a safer quieter cab environment.
The electronics provide remote proportional control of the Feed
Rate and Spinner for your V-Box or Tailgate Spreader.
The PSM1000 System will provide greater return on operator
investment through accuracy in distribution control.

Features and Benefits:

- Complete System with One Part Number
- Electronics, Wire Harness and Hydraulic Manifold Shipped in One Box
- Deutsch and Weather Pak Connectors, You Only Connect Power and Ground
- 500 ms Fixed Ramps for Accel and Decel
- Circuit Protection: If Overload Condition, System Shuts Down; Reset Power Button to Restart.
- Operating Range -40 Degrees F to 180 Degrees F
- IP65 Electronic Enclosure for Splash Proof "Coffee Test"
- "Blast" is a Momentary Button for a 5 Second Duration at Maximum Output with controller on or off for spot applications.
- Back-lit for easy viewing of position in night time operation

Performance Objectives:

- Total System Reliability
- Safer/Quieter Environment
- Improved Cab Ergonomics
- User Friendly

Parker Solution:

- Complete System from Parker
- Removed Hydraulics from Cab with Remote Compact Electronics
- Easy to Operate Controls



PSM1000C

PSM1000C Features:

- Main Power Button
- Temperature Compensated at 200Hz PWM for Stable Electronic Control
- Feed Rate Speed Control – 10 detents
- Spinner Speed Control – 10 detents
- Blast Button – Preset for 5 Second Duration
- EMI/RFI Compliant
- Solid State Circuit Protection
- Wiring Harness Included for Plug-N-Play Capability

PSM1000M Features:

- Feed Rate Proportional Cartridge 16 gpm
- Spinner Proportional Cartridge 7 gpm
- Manual Over-Rides
- Proportional Unloader for Fixed Displacement Pumps
- System Safety Relief in Open Center Systems
- Standard SAE Ports with Gage port added
- 3000 psi Operation
- Load Sense System Capability

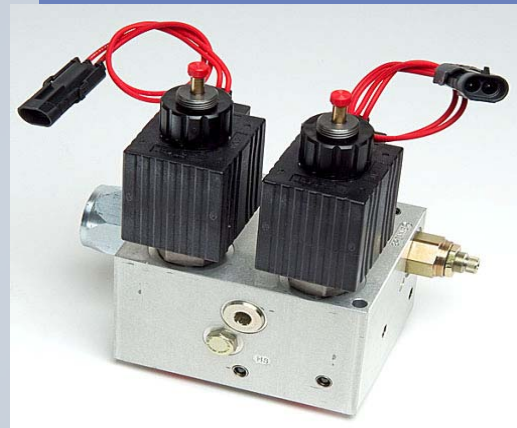

PSM1000M



System #PSM1000 includes:

- Electronic Control Module PSM1000C
- Control Manifold Assembly PSM1000M
- Wiring Harness PSM1000H
- Application Instructions PSM1000AI

System Schematic:

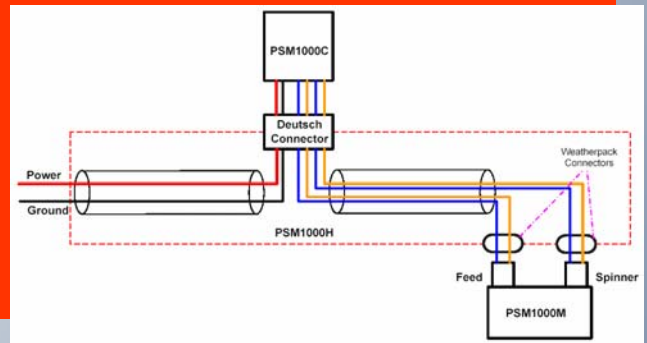

ORDER PART NUMBER:
PSM1000

Parker Hannifin Corporation
 Integrated Hydraulics Division
 595 Schelter Road
 Lincolnshire, Illinois 60069
 (847) 955-5000
 www.parker.com/ihd

HY15-2006/US
 1M 5/06

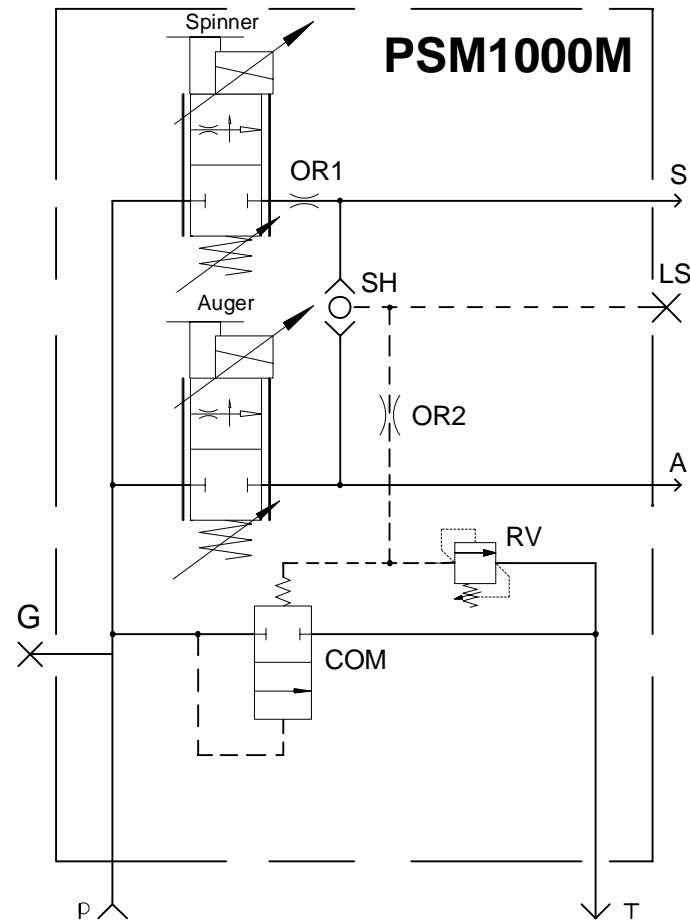

For Open Center Systems

- Designed for Fixed Displacement Pumps
- Power Beyond of Open Center Valve will be plumbed to "P" port of PSM1000M....L.S. port will remain plugged.....
- With series circuit, spool valves will have priority and interrupt flow to PSM1000M spreader requirements.....

For Closed Center Systems with Load Sensing pumps

- Block "T" and connect the LS port to the Pump LS via a LS Shuttle valve, CS041B-A4T, when used in conjunction with any other LS control valve.

PSM1000 APPLICATION INSTRUCTIONS

After the PSM1000 System has been installed, the PSM1000C Controller must be calibrated for the Spreader System in the vehicle.

Calibration controls are found in the rear of the PSM1000C. See below:

MIN Adjustment pot sets the minimum speed the function will operate at when the controller is set to position 1.

Turn clockwise for a higher "I MIN" setting.

MAX Adjustment pot sets the maximum speed the function will operate at when the controller is set to position 10.

Turn clockwise for a higher "I MAX" setting

Max current should not exceed 2.2 amps

*Adjustments should only be made with a small flat head screwdriver

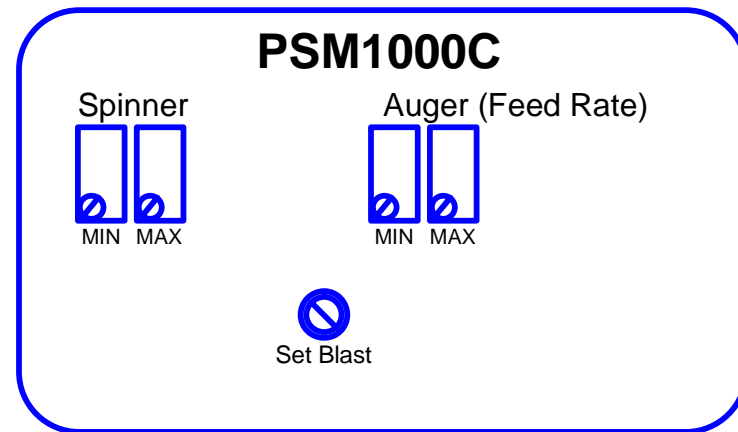

Set Blast controls the current level sent to the Auger control in the "Blast" mode. Set this control for the desired feed rate in the "Blast" mode.

PARKER HANNIFIN CORPORATION		
INTEGRATED HYDRAULIC DIVISION LINCOLNSHIRE, ILLINOIS, USA		
TITLE PSM1000 Application Instructions		
Drawing Number:		PSM1000AI
Date	5/11/06	Rev C

PSM1500-1

Parker Spread Master System
An Auxiliary Spreader Function Option



Customer Value Proposition:

The PSM1500-1 is designed as a low cost auxiliary option to provide reliable application of salt or sand. At the same time, the remote electronics offer a safer, quieter cab environment. The electronics provide remote proportional control of the spinner function for your V-Box or Tailgate Spreader.

The PSM1500-1 System will provide greater return on operator investment through precise, accurate control.



Product Features:

- Complete system with one part number
- Proportional cartridge, 15 GPM
- Deutsch and WeatherPak connectors - You only connect power and ground
- Circuit protection: If overload condition, system shuts down; reset power button to restart

Contact Information:

Parker Hannifin Corporation
Hydraulic Cartridge Systems
595 Schelter Road
Lincolnshire, IL 60069

phone 847-955-5000
HCSInfo@parker.com

www.parker.com/hcs



ENGINEERING YOUR SUCCESS.

PSM1500-2

Parker Spread Master System

Precision Feed Rate and Spinner control at the touch of your fingers.



Customer Value Proposition:

Similar to the PSM1500-1, the PSM1500-2 offers consistent control of the spinner for even application of salt and sand. PSM1500-2 differentiates itself with the addition of the remote electronically proportionally controlled Feed Rate feature.

This integrated package helps provide optimum constant density spreading capability, thus providing maximum cost savings for material and fuel.



Product Features:

- Complete system with one part number
- Proportional cartridge, 15 GPM
- Deutsch and WeatherPak connectors - You only connect power and ground
- Circuit protection: If overload condition, system shuts down; reset power button to restart

Contact Information:

Parker Hannifin Corporation
Hydraulic Cartridge Systems
595 Schelter Road
Lincolnshire, IL 60069

phone 847-955-5000
HCSInfo@parker.com

www.parker.com/hcs



ENGINEERING YOUR SUCCESS.

General Description

The QA and QD Series, Flow Controls are designed for applications such as spreaders where precise control of one or two functions may be required without regard to variations in load pressure. These valves are used mainly on snow removal equipment, but can also be used for other applications such as sand and fertilizer.

Operation

The basic valve consists of at least one or two pressure compensated, priority type flow controls. This valve will provide a constant flow regardless of changes in load or changes in the pump output. Any excess flow from the pump or flow greater than the load requirement will be diverted to the tank port of the valve.

A second pressure compensated, priority type flow control is available. This enables the control of two separate functions. Other options include a relief valve to regulate inlet pressure, a solenoid bypass valve, a manual bypass valve, and a load sensing option.

Features

- Hardened and precision ground parts for durability
- Easy to adjust knobs
- Adjustable flow ranges for varying applications
- Load sense option
- Manual bypass option
- Solenoid bypass option
- Anodized aluminum body for long life

Specifications

Maximum Inlet Flow	150 LPM (40 GPM)
Flow 1 (Spinner) Flow 2 (Auger)	up to 37.5 LPM (10 GPM) up to 112.5 LPM (30 GPM)
Maximum Inlet Pressure	172.5 Bar (2500 PSI)
Flow Accuracy	±5% of setting
Internal Material	Steel
Body Material	Aluminum (anodized)
Operating Temp. Range (Ambient)	-40°C to +93.3°C (-40°F to +200°F) (Nitrile Seals Only)
Approx. Weight	3.2 kg (7.2 lbs.)

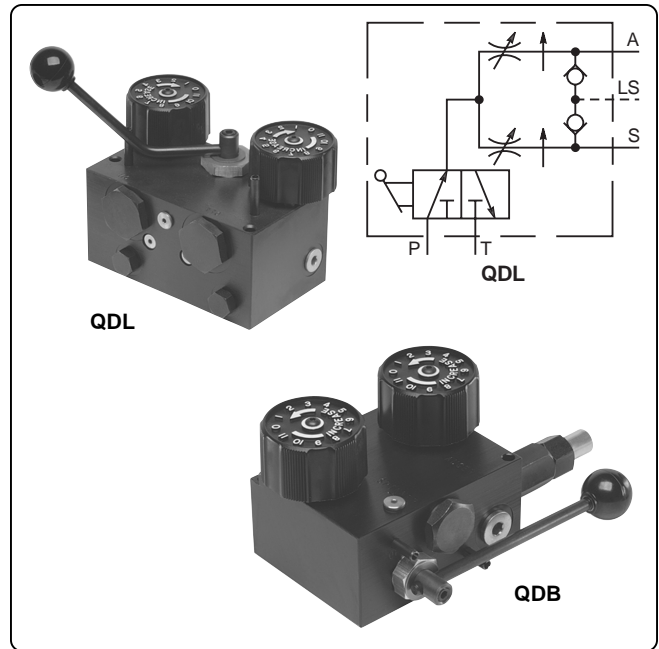

Symbols

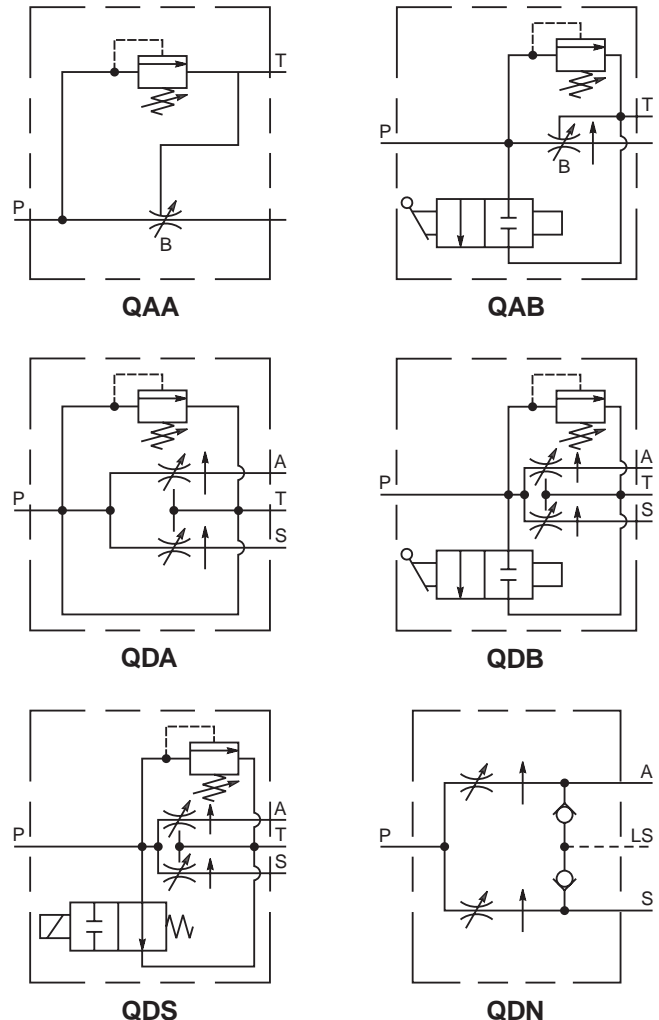

Series QAA and Series QAB
 (For Series QAA, Omit Lever)

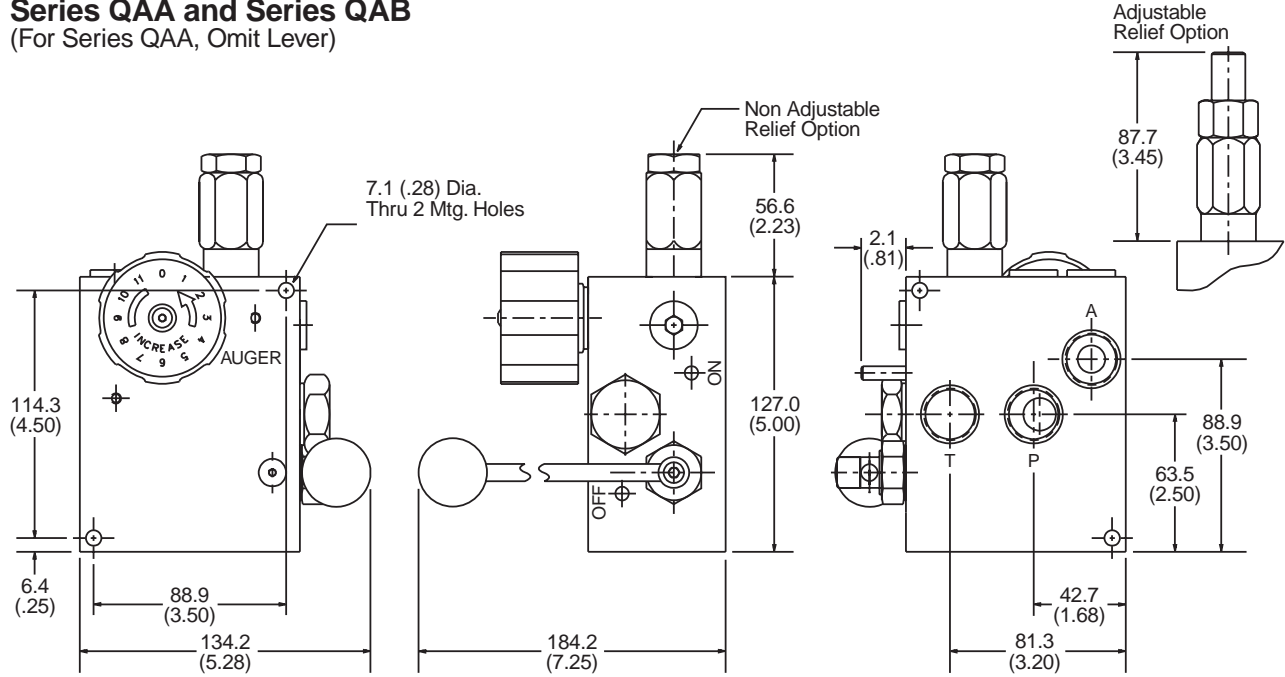

Series QDA

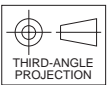
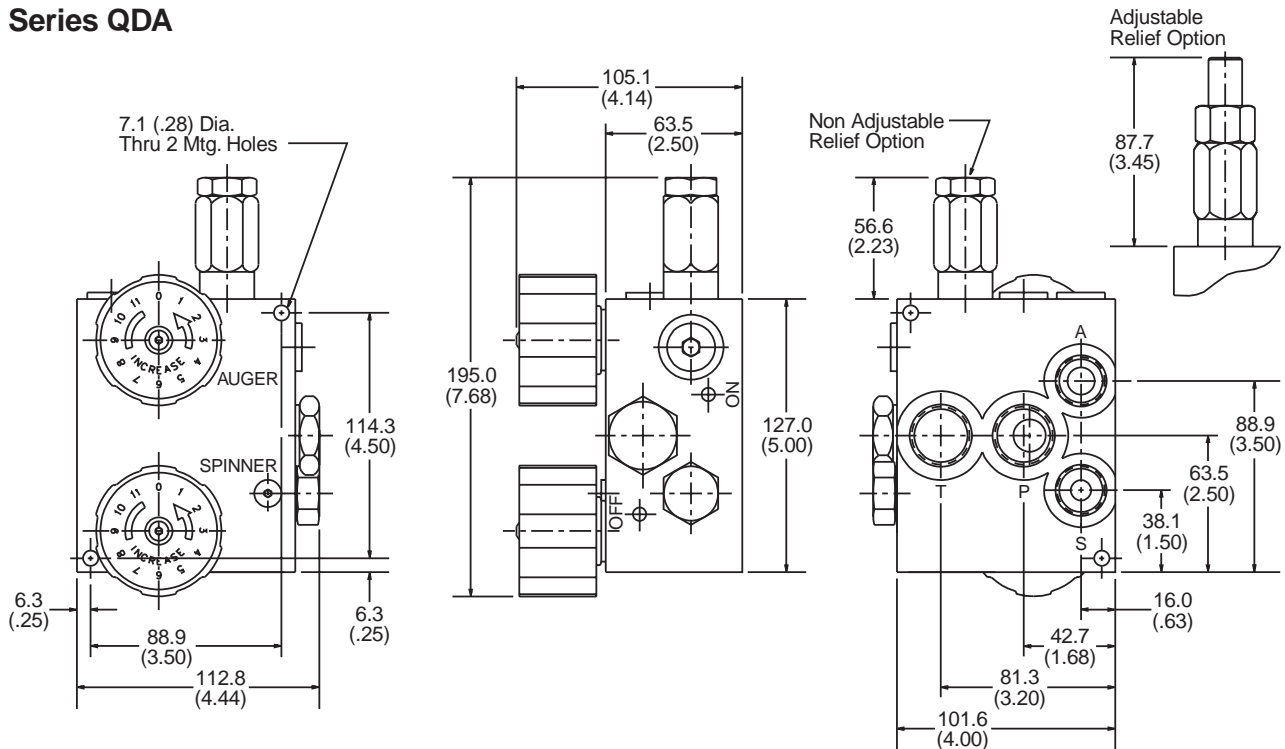

Series QDB

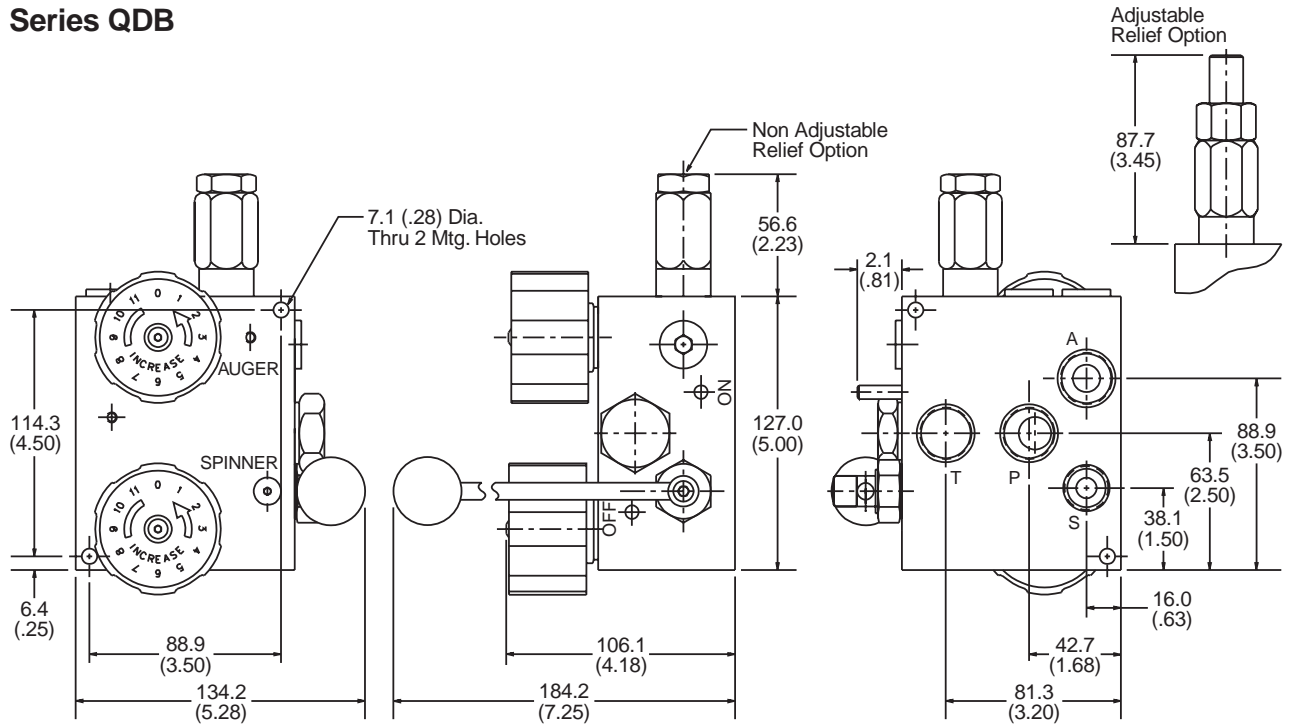

Series QDS

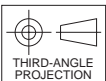
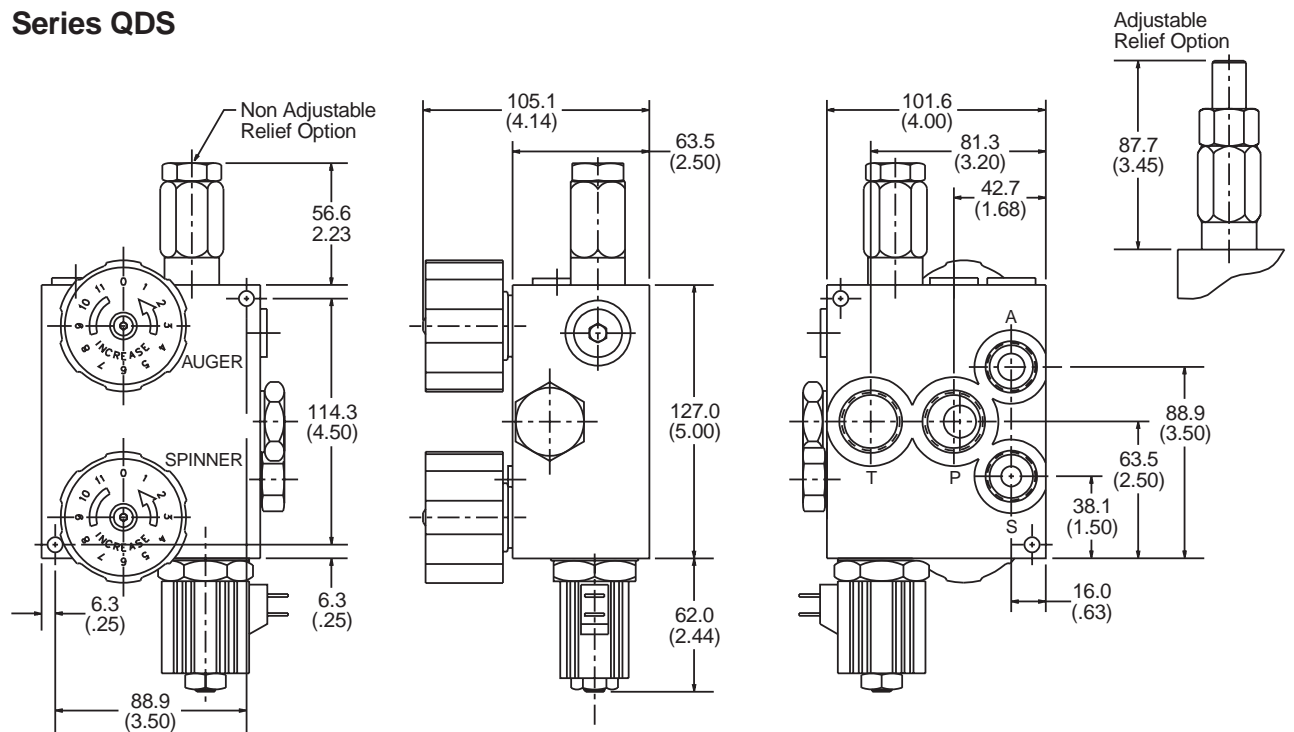

Series QDN

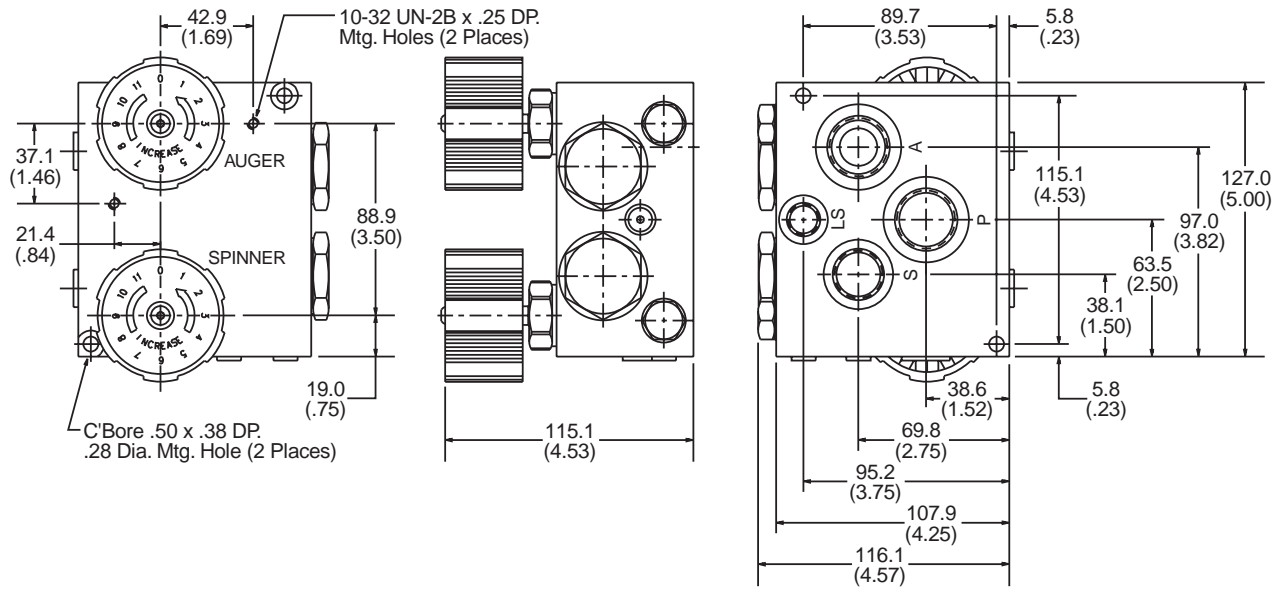

Series QDL

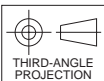
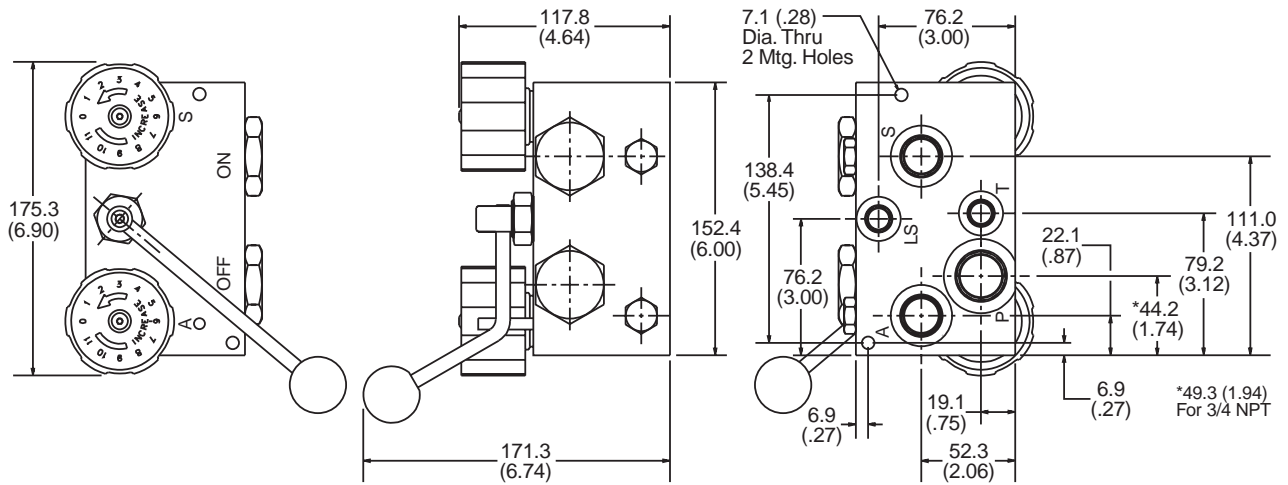

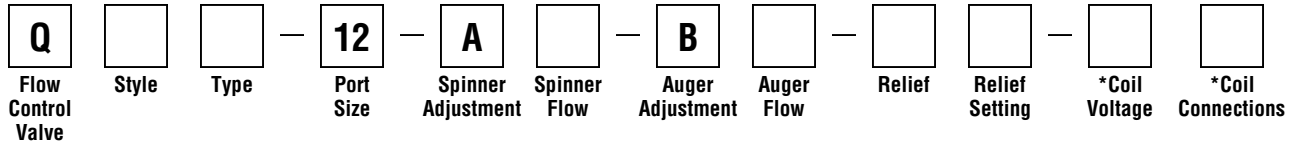

Code	Style
D	Dual Flow Control
A	Single Flow Control

Code	Type
A	Standard (No Shutoff)
B	Manual Shutoff
*L	Load Sensing with Manual Shutoff
*N	Load Sensing
*S	Solenoid Shutoff

* D style only.

Code	Port Size
12	Standard SAE-12 Inlet and Tank Ports SAE-10 Work Ports

Code	Spinner Flow
05	0 thru 18.9 LPM (5 GPM)
07	0 thru 26.5 LPM (7 GPM)
10	0 thru 37.9 LPM (10 GPM)
00	No Flow (A style only)

Code	Auger Flow
10	0 thru 37.9 LPM (10 GPM)
16	0 thru 60.6 LPM (16 GPM)
20	0 thru 75.7 LPM (20 GPM)
*30	0 thru 113.6 LPM (30 GPM)

* Not available on L or N versions.

Code	Relief
NR	No Relief (L and N only)
AR	Adjustable Relief
NA	Non-Adjustable Relief

NOTE: A relief option should be chosen on all types except L and N. Standard factory setting is 2000 PSI if not specified.

Code	Relief Setting
Omit	No Relief
150	103.5 Bar (1500 PSI)
175	120.8 Bar (1750 PSI)
200	138.0 Bar (2000 PSI)
225	155.3 Bar (2250 PSI)
250	172.5 Bar (2500 PSI)

Code	Coil Voltage
Omit	No Coil
12	12 VDC
24	24 VDC

* QDS only.

Code	Coil Connections
Omit	No Coil
B	Dual Spades
D	24" Dual Lead Wires

* QDS only.

SERVICE PARTS

Adjustable Relief Valve: 95018-01
172.4 Bar (2500 PSI)

Solenoid Valve: DS161N

Sales Office

North America
United States, Northeast
phone 847-955-5008
fax 847-383-8900

Supercode Spreader Control valves 090110



Parker Hannifin Corporation
Hydraulic Cartridge System
Division
595 Schelter Rd
Lincolnshire IL 60069
phone 847-955-5000
fax 847-383-8900
www.parker.com

Your Local Authorized Parker Distributor